

OPERATING INSTRUCTIONS

CENTRIFUGAL PUMPS WITH INTEGRATED FREQUENCY DRIVE

VS-SERIES



Contents

1. General	4
1.1 Symbols	4
1.2 Fields of applications	4
1.2.1 AE_-, L_-, AL_- pumps.....	4
1.2.2 AEP-, LP-, ALP- pumps	4
1.2.3 LH-, ALH- pumps	4
1.2.4 LS-, ALS- pumps.....	4
1.3 Limits of application and use	5
1.4 Manufacturer	5
1.5 Version.....	5
2. Handling, transport and storage of the pump.....	5
3. Design and function	6
3.1 Construction	6
3.2 Technical data	6
3.3 Pump identification.....	8
4. Safety	9
4.1 Safety instructions.....	9
4.2 Training.....	9
4.3 Elements of danger if safety regulations are not obeyed.....	9
4.4 Safety instructions for inspection and assembly	10
4.5 Operating the pump	10
5. Installation, introduction and start-up	10
5.1 Positions for installation	11
5.2 Electrical connections.....	11
5.3 Control methods and connections.....	12
5.3.1 I/O's and Kolmek's Factory Defaults of the VS-pump (inputs and outputs)	12
5.3.2 VS-pump monitoring parameters	14
5.3.3 VSA-pump – speed reference from the display	15
5.3.4 VSB-pump – constant pressure between the pump flanges.....	15
5.3.5 VSC-pump - constant pressure in between inlet- and outlet-line	16
5.3.6 VSD-pump - constant pressure in discharge (pressure boosting)	17



5.3.7 VSF-pump - constant temperature.....	17
5.3.8 VSG-pump - controlled by external system	18
5.3.9 VSM-pump – controlled by MODBUS RTU –bus connection	18
6. Service, spare parts and troubleshooting.....	19
6.1 Shaft seals.....	19
6.2 Other parts	20
6.3 Troubleshooting.....	21
6.4 Checking of alarm history	25
6.5 Alarm and fault codes.....	25
7. Declaration of Conformity.....	29
8. Annex	30
8.1 Wiring diagram VSA-single pump.....	30
8.2 Wiring diagram VSB-single pump.....	31
8.3 Wiring diagram VSC-single pump	32
8.4 Wiring diagram VSD-single pump	33
8.5 Wiring diagram VSF-single pump.....	34
8.6 Wiring diagram VSG-single pump	35
8.7 Wiring diagram VSM-single pump.....	36

1. General

1.1 Symbols



Warns that failure to observe the precaution may cause personal injury or damage to property.



Warns that failure to observe the precaution may cause electric shock.

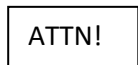

Indicates something to be noted by the reader.

1.2 Fields of applications

The most common applications are heating, air condition, cooling systems. Also heat exchangers, pressure boosting systems, district heating systems, ice halls, public baths and industrial processes.

1.2.1 AE_-, L_-, AL_- pumps

Clean, thin, non-aggressive liquids.

- circulating water in for heating and cooling systems
- water-glycol mixtures

1.2.2 AEP-, LP-, ALP- pumps

Clean, thin, slightly aggressive liquids.

- domestic hot water, oxygen rich waters, sea water, etc.

1.2.3 LH-, ALH- pumps

- as in L- and AL -series, but nominal pressure 16 bar

1.2.4 LS-, ALS- pumps

Aggressive, thin, not bigger solid particles containing liquids

- in addition to above mentioned liquids various acids, salts, oxidizing and chemically active organic fluids

1.3 Limits of application and use

Nominal pressure: AE-, AEP-, L-, AL-, ALP- pumps: 10 bar
LH-, ALH-, LS- and ALS-pumps: 16 bar
Medium temperature range: -10 ... + 90 °C
Ambient temperature: 0 ... +40°C (diurnal average max. +35°C)

ATTN



Suitability of materials and seals for pumped liquid shall be always checked between purchaser and supplier. The nominal pressure and the max. temperature of pumped liquid are stamped on the pump rating plate. Never use the pump in any other application or conditions without manufacturer's acceptance. In the case of damage there may be danger to persons by having poisoning, burns, wounds etc. depending on the pumped liquid and it's temperature and pressure. The pump surface temperature may cause danger depending on the working conditions.

1.4 Manufacturer

This product is manufactured by KOLMEKS OY, P.O.BOX 27, FIN-14201 TURENKI, FINLAND.

1.5 Version

Release date of this manual is 4.6.2019. This is version no. 6.

2. Handling, transport and storage of the pump

ATTN!

Normally the pumps are stable when they are transported and don't go down even they are bent 10°. Pumps shall be stored in a dry and cool place protected from dust. Temperature of environment must be in -10 °C ... +50°C. It is not allowed to lift the pump from frequency converter. In the case of longer storage time or the pump serves as a stand-by, it is recommended to rotate the pump manually eg. from the motor fan at least once a month.

3. Design and function

3.1 Construction

The pump and motor constitute a unit, where the rotating parts of both the pump and the motor are on the same shaft (mono-block design). The motor is of a dry type and the frequency converter is integrated to the electric motor.

Electric motor: Totally enclosed, fan cooled A.C. motor, with frequency converter.
 Protection form: IP54
 Insulating class: F

3.2 Technical data

Pump type	Connection	Hz max	Nominal power P _{2n} kW	Supply current A 1 x 230 V	Weight kg
AE_/AEP-26/2VS	1"	50	0,65	3,0	20
AE_/AEP-33/2VS	1 1/4"	65	1,1	4,0	27
AE_/AEP-33/2VS	1 1/4"	50	1,5	4,0	38
L_-32A/2VS	DN32	50	0,65	3,0	27
L_-32A/2VS	DN32	60	1,1	4,0	30
L_-40A/2VS	DN40	50	1,1	4,0	32
L_-40A/2VS	DN40	50	1,5	4,0	43
L_/LP-50A/4VS	DN50	55	0,55	2,2	42
L_/LP-50A/4VS	DN50	63	0,9	3,0	42
L_/LP-50B/2VS	DN50	50	1,1	4,0	36
L_/LP-50D/2VS	DN50	50	2,2	7,3	49
L_/LP-50D/2VS	DN50	50	3,0	9,6	55
L_-65A/4VS	DN65	50	0,55	2,2	48
L-65A/4VS	DN65	60	0,9	3,0	48
L_-65A/4VS	DN65	60	1,5	4,0	57
L_-65A/4VS	DN65	65	3,0	9,6	64
L_-65B/2VS	DN65	50	3,0	9,6	64
L_-65B/2VS	DN65	50	4,0	11,5	72
L_-65B/2VS	DN65	50	5,5	14,2	96
L_-65B/2VS	DN65	50	7,5	20,0	104

Noise level of all pump types is under 80 dB (A, 1 m). Weight is without transmitter.

Pump type	Connection	Hz max	Nominal power P _{2n} kW	Supply current A 1 x 230 V	Weight kg
L_-80A/4VS	DN80	50	0,75	3,0	52
L_-80A/4VS	DN80	50	1,5	4,0	60
L_-80A/4VS	DN80	63	3,0	9,6	66
L_-80A/2VS	DN80	50	4,0	11,5	73
L_-80A/2VS	DN80	50	5,5	14,2	97
L_-80A/2VS	DN80	50	7,5	20,0	105
L_-100S/4VS	DN100	50	4,0	11,5	175
L_-100S/4VS	DN100	50	5,5	14,2	185
L_-100S/4VS	DN100	50	7,5	20,0	210
AL_/ALP-1102/4VS	DN100	50	0,75	3,0	66
AL_/ALP-1102/4VS	DN100	50	1,5	4,0	69
AL_/ALP-1102/4VS	DN100	60	3,0	9,6	75
AL_/ALP-1102/2VS	DN100	50	5,5	14,2	107
AL_/ALP-1102/2VS	DN100	50	7,5	20,0	114
AL_-1129/4VS	DN125	50	4,0	11,5	174
AL_-1129/4VS	DN125	50	5,5	14,2	181
AL_-1129/4VS	DN125	50	7,5	20,0	208
AL_-1154/4VS	DN150	50	7,5	20,0	221

3.3 Pump identification

Marks for accessories:

T = external mechanical seal for aggressive medium

H = flush for mechanical seal

KT = double mechanical seal

Sn = different mechanical seal

Kn = different surface treatment

Different material of impeller:

PM = Bronze CuSn10

SS = Stainless steel AISI316

Pump type	Pump L-80A/2VSC (5/10)	N151503	Motor code
Serial number, Nominal pressure	No 070471.22 2015 PN 10	Ø 166 mm	Impeller size
Duty point, Max. medium temperature	14,03 l/s 25m 90 °C	P1 kW	Electrical power at duty point
Motor type	Motor KPVS-132E1F19	1~ 50Hz S1	Phases, frequency and duty
Nominal voltage and current	400 V 20,0A_{max} P2N 7,5 kW	10-50 r/s	Nominal shaft power
Rotating speed range, isolating and enclosure glass	Isol F IP54	MEI ≥ 0,4 --	
Manufacturer, country of origin	 KOLMEKS Finland	D 6307-DDUC4ENS N 6307-DDUC3E	Bearing types, CE -marking

AL - 110 2 / 4 VS B

L P - 50 A / 4 VS C

Pump series:

AE-, L-, AL-

Material of pump housing, sealing flange and impeller:

no letter = grey cast iron EN-GJL-200 / 10 bar

H = nodular cast iron EN-GJS-400 / 16 bar

P = bronze CuSn10 / 10 bar

S = stainless steel AISI 316 / 16 bar

Flange size, DN-size:

20 = 3/4"

25 = 1"

32 = DN 32

40 = DN 40

50 = DN 50

65 = DN 65

80 = DN 80

110 = DN 100

112 = DN125

115 = DN150

Poles of the electric motor:

2 = rotation speed 50 r/s (50 Hz)

rotation speed 60 r/s (60 Hz)

4 = rotation speed 25 r/s (50 Hz)

rotation speed 30 r/s (60 Hz)

rotation speed 31.5 r/s (63 Hz)

rotation speed 32.5 r/s (65 Hz)

VS = VS - the frequency converter is integrated to the pump:

VSA, VSB, VSC, VSD, VSF, VSG, VSM (check 5.3 *Control methods and connections*)

(5/10) => VSB ja VSC: 5 = measure range of differential pressure [bar], 10 = measure range of pressure transmitter [bar]

4. Safety

This manual includes important information concerning installation and operating the pump. Persons who are involved in installation or/and operation of the pump, should read and understand these instructions before installation or starting the pump.



There are live parts inside the frequency converter of the VS -pump, when the supply voltage is connected. Incorrect installation of VS –pump may cause damage to the pump or bodily injuries, even death. Touching the live parts may be mortal even the supply voltage is disconnected. Obey instructions of this manual and national and local requirements and standards.

Wait at least 4 minutes!

- installation must be protected by fuses and insulated correctly.
- covers and cable inlets must be installed.

ATTN!

It is user's or certified electrician's responsibility to ensure the correct earthing and protection in accordance with applicable national and local requirements and standards.

4.1 Safety instructions

1. VS-pump must be disconnected from the mains if repair work is to be carried out. Check that the mains supply has been disconnected and necessary time has passed (at least 10 minutes).
2. The device must be connected correctly to the earth. User must be protected from supply voltage and the pump must be protected from short circuit according to the national and local requirements and standards. The overload protection is included in VS -pump.
3. Earth leakage is more than 3,5 mA. It means, that installation of supply cable must be fixed.

4.2 Training

The persons who have responsibility for installing or/and operating the pump, should be trained.

4.3 Elements of danger if safety regulations are not obeyed

If the safety regulations are not obeyed, personal injuries or damage to the pump or related devices may occur. Valid safety instructions must be obeyed.

4.4 Safety instructions for inspection and assembly

It is user's responsibility to ensure that persons who carry out inspections and installations are qualified experts and familiarized themselves with these instructions carefully.

4.5 Operating the pump

Working safety of the delivered pump and related devices can be ensured only if these devices are operated according to the section *1.2 Fields of application* and *1.3 Limits of application* and use of this manual.

5. Installation, introduction and start-up

The pump can be installed to the piping without separate supporting.

The position of the motor unit with the frequency converter can be changed by removing the motor unit from the pump housing and setting it to the desired position with certain limitations.

When installing the pump pay attention to the following:

- space enough for service and inspection of the pump
- free visibility to the display of the potentiometer
- free visibility to the rating plate of the pump.
- possibility to use lifting mechanism if needed
- shut-off valves on the both sides of the pump
- the frequency converter is not too close hot pipes.

5.1 Positions for installation

Allowed positions

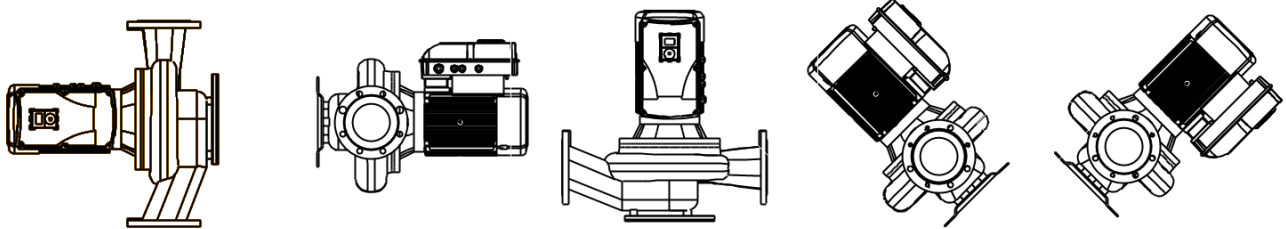

Not allowed positions

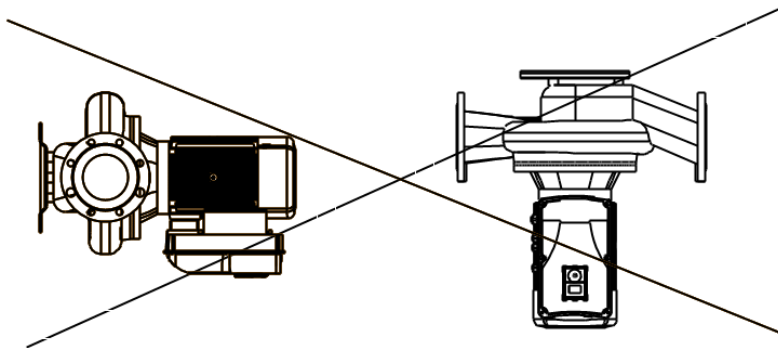

5.2 Electrical connections

ATTN!

All electrical work shall be carried out by qualified electrician approved by the local authorities. Supply voltage should be connected with screened cable like MCCMK. Ensure the nominal voltage of the electric motor corresponds the local supply voltage.

ATTN!

Use always Screened control cables.

Before starting the pump fill and vent the system. Make sure that the pump rotates freely by rotating it manually eg. from the motor fan. Never start or let the pump run dry. The warranty doesn't cover failures in the mechanical seal caused by dry running. Before starting the pump fill and vent the system. After starting make sure that there is no extra noise coming from the pump and that no leakages appear.

ATTN!

This product can cause a d.c. current in the protective grounding conductor. If residual current device (RCD) has been connected to supply side of the product, only B-type RCD is allowed to be used

5.3 Control methods and connections

5.3.1 I/O's and Kolmeks Factory Defaults of the VS-pump (inputs and outputs)

Terminal	Signal	Kolmeks Factory Default	
A	RS485	Serial -	
B	RS485	Serial +	
1	+10Vref	+10 V reference voltage	
2	AI1+	Analogue input 1 voltage or current	A-, B- and C-versions: Current (SW 2 + P3.1) D- and G-versions: Voltage (SW2 + P.3.1)
3	AI1- /GND	AI1-	
6	24Vout	+24 V, loadability 100mA	
7	DIN COM	Digital input common	
8	DI1	Digital input 1	Run / Stop (P4.1 - P4.18) *
9	DI2	Digital input 2	PID-Controller (P4.1 - P4.18) *
10	DI3	Digital input 3	Preset speed, 40 Hz (P4.1 - P4.18) *
4	AI2+	Analogue input 2 voltage or current	Current (SW 3 + P3.5)
5	AI2- /GND	AI2-	
13	DO1-	Digital output -	
14	DI4	Digital input 4	Not in use(P4.1 - P4.18) *
15	DI5	Digital input 5	Fault reset (P4.1 - P4.18) *
16	DI6	Digital input 6	NC External fault (P4.1 - P4.18) *
18	AO1+	Analogue output	Output Frequency 0 - f_{max} , 0 - 10V (P6.1)
20	DO1+	Digital output +	Not in use
*) Parameter group 4 operations are activated by choosing digital inputs with parameters 4.1 - 4.18			

6b

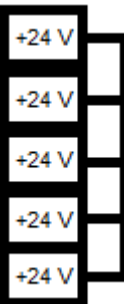

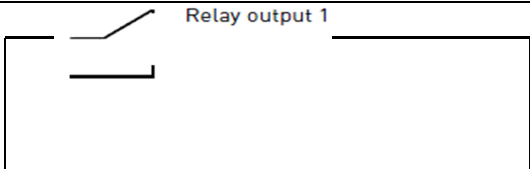
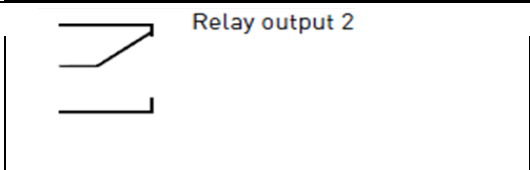
22	RO1/2	 Relay output 1	Run
23	RO1/3		
24	RO2/1	 Relay output 2	Fault
25	RO2/2		
26	RO2/3		

Dip switch	Operation	Factory Default
SW 1	Digital input COM (terminal 7) can be isolated from GND by setting SW1 to position "1"	SW1 = 0
SW 2	Analogue input 1 operation mode selection either to current or voltage. When the switch is in position "0", AI1 operates as current input (0/4-20 mA). When the switch is in position "1", AI1 operates as voltage input(0-10V)	SW2 = 0 A,- B- and C-versions SW2 = 1 D- and G-versions
SW 3	Analogue input 2 operation mode selection either to current or voltage. When the switch is in position "0", AI2 operates as current input (0/4-20 mA). When the switch is in position "1", AI2 operates as voltage input(0-10V)	SW3 = 0
SW 4	The Switch SW4 is related to RS485 connection, It's used for bus termination. The bus termination must be set to the first and last device on the network. The switch SW4 in position "0" means that termination resistance is connected and the termination of the bus has been set. If the VS-pump is the last device on the net, this switch must be set to "0" position.	SW4 = 0

5.3.2 VS-pump monitoring parameters

While VS-pump is running following frequency converter actual values can be seen from frequency converter 'M'-menu.

Monitoring parameters ('M'-menu):				
Code	Monitoring value	Unit	ID	Description
V1.1	Output frequency	Hz	1	Output frequency to motor
V1.2	Frequency reference	Hz	25	Frequency reference to motor control
V1.3	Motor shaft speed	rpm	2	Motor speed in rpm
V1.4	Motor Current	A	3	
V1.5	Motor Torque	%	4	Calculated shaft torque
V1.6	Motor Power	%	5	Total power consumption of AC drive
V1.7	Motor Voltage	V	6	
V1.8	Motor temperature	%	9	Calculated motor temperature
V1.9	DC-link Voltage	V	7	
V1.10	Unit temperature	°C	8	Heatsink temperature
V1.11	Board temperature	°C	1825	Power board temperature
V1.12	Analogue input 1	%	13	Analogue input AI1
V1.13	Analogue input 2	%	14	Analogue input AI2
V1.14	Exp. Analogue input	%	1837	Analogue input on OPTB4
V1.15	Analogue output	%	26	Analogue output
V1.16	Exp. Analogue out 1	%	1838	Analogue output 1 on OPTB4-BF
V1.17	Exp. Analogue out 2	%	1839	Analogue output 2 on OPTB4
V1.18	DI1, DI2, DI3		15	Digital inputs status
V1.19	DI4, DI5, DI6		16	Digital inputs status
V1.20	DI7, DI8, DI9		1835	Digital inputs on OPTB1 status
V1.21	DI10, DI11, DI12		1836	Digital inputs on OPTB1 status
V1.21	RO1, RO2, DO		17	Digital outputs status
V1.23	EO1, EO2, EO3, EO4		1852	Expansion board digital outputs status
V1.24	Process variable		29	Scaled process variable. See P7.10
V1.25	PID setpoint	%	20	PID controller setpoint
V1.26	PID error value	%	22	PID controller error
V1.27	PID feedback	%	21	PID controller actual value
V1.28	PID output	%	23	PID controller output
V1.29	Temperature sensor 1	°C or °K	1860	OPTBH sensor 1
V1.30	Temperature sensor 2	°C or °K	1861	OPTBH sensor 2
V1.31	Temperature sensor 3	°C or °K	1862	OPTBH sensor 3
V1.32	ASi board state		1894	OPTBK state

NOTE! All monitoring parameters may not be visible, if option board isn't connected or PID-controller is disactivated (Digital input 2)

5.3.3 VSA-pump – speed reference from the display

Applications

Systems, where the duty point remains constant and where is no need for continuous automated regulation.

Accessories

Pump and frequency converter.

Operation principle

The speed of electric motor can be adjusted manually at the site during commissioning of the pump. The pump will run with constant speed. The required speed is selected by pushing button *BACK/RESET-button* until can be selected either 'R', 'M', 'P' or 'S'. From these is selected 'R' (=Reference) and pressed 'OK'. Frequency reference is selected with Arrow-buttons and confirmed by pushing 'OK' –button. While pump is running, frequency converter actual values can be researched from 'M'-menu (=Monitoring)

Pump curve

QH-curve of the pump is equal with that of single speed pump.

Standard control connections (see ANNEX 8.1 VSA-wiring diagram)

5.3.4 VSB-pump – constant pressure between the pump flanges

Applications

Systems, where are variations in the flow and where pressure losses are generated mainly on the consumption equipment. Heating circulation, where the pressure loss on the heat equipment is small.

Accessories

Pump, frequency converter, 2 pcs of pressure transmitters installed to the pump flanges.

Operation principle and flow adjustment

The level of the constant pressure difference between the pump flanges can be adjusted by the controller of frequency converter (parameter P.12.2). By pushing button *BACK/RESET-button* until can be selected either 'R', 'M', 'P' or 'S'. From these is selected 'P' (=Parameters) and pressed 'OK'. With Arrow-buttons is searched parameter P.12.2. By pushing 'OK' –button, appears value of the parameter P12.2 to the display which is reference for PI –controller (constant differential pressure). The required reference value can be adjusted by the *Up-* and *Down-*arrow buttons. It is saved by pushing 'OK' –button. Value is percents of max. measuring value. For Example when using 10 bar Pressure Transmitters the Pressure Difference 5 bars = 100 %. With 6 bar Transmitters the difference 3 bars = 100% and so on. After the set point is saved, by pushing button *BACK/RESET-button* twice, starting situation is achieved. While pump is running, frequency converter actual values can be researched from 'M'-menu (=Monitoring)

Pump curve

QH-curve of the pump is controlled to a horizontal line, which is suitable for systems with low pressure loss share in heat exchanger compared to the total pressure loss.

Standard control connections (see ANNEX 8.2 VSB-wiring diagram)

5.3.5 VSC-pump - constant pressure in between inlet- and outlet-line

Applications

Systems, where are variations in the flow and where pressure losses are generated mainly on the source of heat equipment. Heating and cooling circulations and the pressure boosting of parallel circulations.

Accessories

Pump, frequency converter and 2 pcs of pressure transmitters. Another transmitter to be installed to the suction or pressure flange of the pump and another one on to the system inlet or outlet pipe.

Operation principle and flow adjustment

The level of the constant pressure difference between the inlet and outlet line can be adjusted by the controller of frequency converter (parameter P.12.2). By pushing button *BACK/RESET-button* until can be selected either 'R', 'M', 'P' or 'S'. From these is selected 'P' (=Parameters) and pressed 'OK'. With Arrow-buttons is searched parameter P.12.2. By pushing 'OK' -button, appears value of the parameter P12.2 to the display which is reference for PI -controller (constant differential pressure). The required reference value can be adjusted by the *Up-* and *Down-arrow* buttons. It is saved by pushing 'OK' -button. Value is percents of max. measuring value. For Example when using 10 bar Pressure Transmitters the Pressure Difference 5 bars = 100 %. With 6 bar Transmitters the difference 3 bars = 100% and so on. After the set point is saved, by pushing button *BACK/RESET-button* twice, starting situation is achieved. While pump is running, frequency converter actual values can be researched from 'M'-menu (=Monitoring)

Pump curve

QH-curve of the pump is controlled to a quadratic. The relation of pressure loss in the source of heat (cold) to the loss in the system defines the shape of the curve. When the losses in the heat exchanger are large part of the whole losses in the system the curve is more steep.

Standard control connections (see ANNEX 8.3 VSC-wiring diagram)

5.3.6 VSD-pump - constant pressure in discharge (pressure boosting)

Applications

Pressure boosting or other open systems, where constant pressure is required.

Accessories

Pump, frequency converter and pressure transmitter. The pressure transmitter is installed to the pressure flange of the pump or near to the consumption in the pipe line.

Operation principle

The level of the constant pressure in discharge can be adjusted by the controller of frequency converter (parameter P.12.2). By pushing button *BACK/RESET-button* until can be selected either 'R', 'M', 'P' or 'S'. From these is selected 'P' (=Parameters) and pressed 'OK'. With Arrow-buttons is searched parameter P.12.2. By pushing 'OK' –button, appears value of the parameter P12.2 to the display which is reference for PI –controller (constant pressure). The required reference value can be adjusted by the *Up-* and *Down-*arrow buttons. It is saved by pushing 'OK' –button. Value is percents of max. measuring value (mentioned in transducer). After the set point is saved, by pushing button *BACK/RESET-button* twice, starting situation is achieved. While pump is running, frequency converter actual values can be researched from 'M'-menu (=Monitoring)

Standard control connections (see ANNEX 8.6 VSD-wiring diagram)

5.3.7 VSF-pump - constant temperature

Applications

Heating and cooling systems, where the constant temperature is required by adjusting the flow.

Accessories

Pump, frequency converter and temperature transmitter (and sensor).

Operation principle

The level of the constant temperature can be adjusted by the controller of frequency converter (parameter P.12.2). By pushing button *BACK/RESET-button* until can be selected either 'R', 'M', 'P' or 'S'. From these is selected 'P' (=Parameters) and pressed 'OK'. With Arrow-buttons is searched parameter P.12.2. By pushing 'OK' –button, appears value of the parameter P12.2 to the display which is reference for PI –controller (constant temperature). The required reference value can be adjusted by the *Up-* and *Down-*arrow buttons. It is saved by pushing 'OK' –button. Value is percents of max. measuring value (mentioned in transducer). After the set point is saved, by pushing button *BACK/RESET-button* twice, starting situation is achieved. While pump is running, frequency converter actual values can be researched from 'M'-menu (=Monitoring)

ATTENTION! When ordering the pump, the response of the control must be informed. In the heating system the response is normal, in the cooling system inverse. *Normal*, the pumping goes down, when the temperature (feedback) goes up, *inverse*, the pumping goes up, when the temperature (feedback) goes up (par. P.12.10 => normal = 0, inverse = 1).

Standard control connections (see ANNEX 8.7 VSF-wiring diagram)

5.3.8 VSG-pump - controlled by external system

Applications

Systems, where are variations in the flow and/or where the flow is controlled mainly with the pump. The pump is controlled by an external system or controller.

Accessories

Pump and frequency converter.

Operation principle

The speed reference for pumps is given to Analogue input 1 (0-10 V) from external control system, external controller, process control, etc

ATTENTION!! If the external control system is not in use when pumping is needed Frequency reference source must be changed; Parameter P.1.12 is changed 0 → 4. After the change Frequency reference is set as in 5.3.3 *VSA-pump – speed reference from the display.*

Standard control connections (see ANNEX 8.8 VSG-wiring diagram - with external controller in use)

5.3.9 VSM-pump – controlled by MODBUS RTU –bus connection

Applications

Systems, where are variations in the flow and/or where the flow is controlled mainly with the pump. The pump is controlled by an external system or controller.

Accessories

Pump and frequency converter.

Operation principle

All control, adjusting and indications are taken care with MODBUS RTU –bus connections.

Standard control connections (see ANNEX 8.9 VSM-wiring diagram - MODBUS RTU –bus connection)

5.3.10 Local Control Panel

The VS -pump optionally features a separate cable connected Local Control Panel, which makes up the complete interface for operation and monitoring of the VS -pump. If the pump is located such as the display is hard to see, it helps the parameterizing of the frequency converter.

6. Service, spare parts and troubleshooting

The pump doesn't need any regular servicing. As a shaft seal is used an adjustment free mechanical seal. It is a wearing part which has to be replaced if it starts to leak. Note that few drops leakage per hour can be quite normal especially when coolants (eg. glycol) are pumped.

6.1 Shaft seals

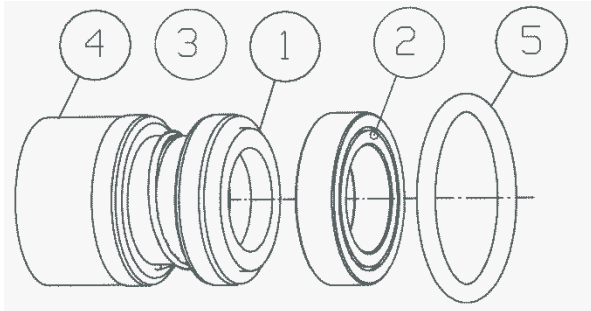

Pump type	Shaft mm	O-ring mm
AE_-25/-26 VS_	12	123x2,5
L_-32A VS_	12	100x2,5
L_-40A, AE_-32/-33 VS_	12	145x2,5
L_-50A VS_	12	150x3
L_-65A, L_-80A, AL_-1102 VS_	18	179,3x5,7
L_-100S VS_	32	315x6,3
AL_-1129 VS_	32	309/295 x 1
AL_-1154 VS_	32	309/295 x 1

- 1 Rotating ring
- 2 Stationary ring
- 3 Body / bellows
- 4 Spring
- 5 O-ring

The motor is equipped with ball bearings which are lubricated for life and therefore do not need any service. In the case of any motor malfunction it is recommended to replace the whole motor unit.

6.2 Other parts

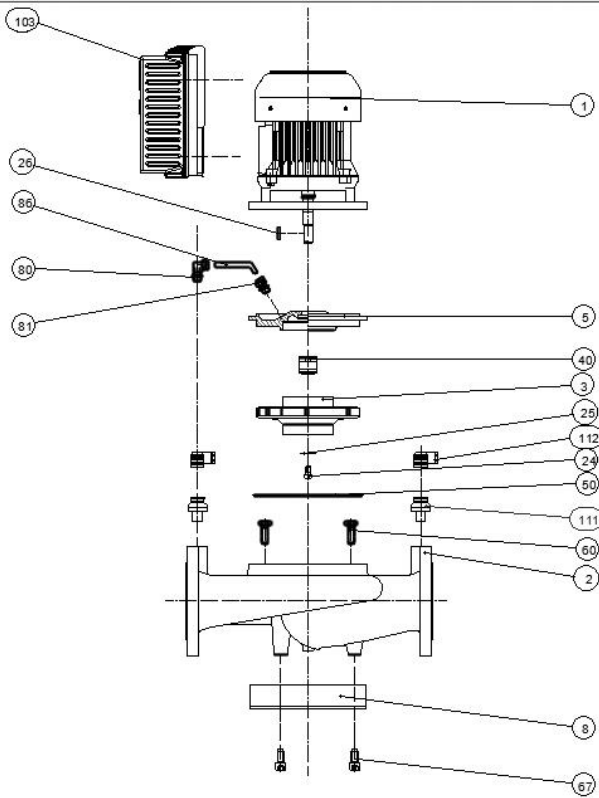

- 1 Electric motor
- 2 Pump housing
- 3 Impeller
- 5 Sealing flange
- 8 Foot (not always)
- 24 VSrew or nut
- 25 Washer
- 26 Key
- 40 Shaft seal
- 50 O-ring or gasket
- 60 VSrew or nut
- 67 VSrew
- 80 Pipe union (L- and ALH -serie)
- 81 Pipe union (L- and ALH -serie)
- 86 Cooling pipe (L- and ALH -serie)
- 103 Frequency converter
- 111 Transmitter quick connector(VSB, VSC, VSD)
- 112 Transmitter(s) for pressure, pressure difference or temperature (VSB, VSC, VSD, VSF)

ATTN!

WHEN ORDERING SPARE PARTS, PLEASE SPECIFY THE TYPE IDENTIFICATION, SERIAL NUMBER, THE SIZE OF THE IMPELLER, THE MOTOR TYPE AND POWER AND THE POSITION NUMBER OF THE SPARE PART.

6.3 Troubleshooting

Trouble	Fault	Fixing
Shaft seal is leaking.	Wearing.	Change the seal.
	Pump has run dry.	Change the seal.
Pump doesn't run.	The shaft of the pump is blocked.	Check the free rotation of the shaft by turning the motor fan. If required, loosen the motor unit from the pump housing and repair the cause of the block.
	Fuses have worked.	Repair the cause of the fault. Change the fuses. If necessary, call the expert.
	No electricity.	Check and repair connections. If necessary, call the expert.
	The disorder has stopped the pump.	Reset the pump by disconnecting the supply voltage at least for 10 seconds.
	Control wiring is not correct.	Check the wiring in accordance with the control diagram. Between terminals PC-STF must be jumpered or closed switch.
	The parameters of the frequency converter are changed or the pump is stopped with local control panel.	Correct the parameters or start the pump with the local control panel (not included in standard delivery). If necessary, call the expert.
	The frequency converter or electric motor is damaged.	Replace the frequency converter and/or electric motor with a new one. Contact to KolmekS.
ATTN!	If the pump is operated when cover of the frequency converter is open, the special carefulness must be observed.	
Pump stops by itself or runs irregular and noisy.	The supply voltage is defective. One phase is possible missing.	Check the supply voltage. Check and repair fuses and connections of the cables.
	The frequency converter or electric motor is damaged.	Replace the complete motor unit with frequency converter with a new one. Contact to KolmekS.

Trouble	Fault	Fixing
The pump is running with minimum frequency.	The reference value is missing or in minimum.	Adjust the correct value with the buttons of the local control panel (if intention to use the local reference as source of the reference). Check and correct the reference if the reference is given by external controller.
	The pipes of the pressure or differential pressure transducer are blocked or incorrectly connected.	Check and repair the connections and blockings of the pipes. Open the possible valves, which are installed to the pipes.
	The signal of the feedback transmitter (pressure or temperature) is too high. Possible short circuit.	Disconnect the cable from the transmitter, the speed should increase, if there is a fault in transmitter or the signal (not VSF cooling system). Check the connections, transmitter. If necessary, replace the transmitter with the new one.
	The mechanical or electrical connections of the temperature transmitter of the VSF -pump are incorrect or the transmitter is damaged.	Check and repair of the connections or the transmitter.
	Parameters of the VSF -pump are wrong (cooling and heating pumps have different parameters)	Check and correct the parameters. If necessary, call the expert.
	VSB or VSC –pump: The lower pressure transmitter gives the full signal (20 mA) or the higher pressure transmitter gives no signal.	Check the connections and transmitters. Measure the signals of the transmitter and if needed, change the transmitter.
The pump is running only with the maximum frequency, which don't vary in accordance with the requirements of flow changes.	Reference signal is too high.	Adjust the correct value with the buttons of the local control panel (if intention to use the local reference as source of the reference). Check and correct the reference if the reference is given by external controller.
	Feedback transmitter is missing or the signal is wrong	Check and repair the feedback signal and/or connections. If necessary, replace the transmitter with the new one.

	The pipes of the pressure or differential pressure transducer are blocked or incorrectly connected.	Check and repair the connections and blockings of the pipes. Open the valves, which may be installed to the pipes.
Trouble	Fault	Fixing
The pump is running only with the maximum frequency, which don't vary in accordance with the requirements of flow changes.	The mechanical or electrical connections of the temperature transmitter of the VSF -pump are incorrect or the transmitter is damaged.	Check and repair of the connections or the transmitter.
	Parameters of the VSF -pump are wrong. (cooling and heating pumps have different parameters)	Check and correct the parameters with the local control panel. If necessary, call the expert.
	The maximum speed is required by the system.	Check the adjustments and the need of the pumping in the system. Balance the parallel circulations. It can be the normal situation, then there is no need for any further measures. Solve the actual rotation speed by measuring or with the local control panel. Contact to Kolmek. Maximum frequency is not allowed to change (factory default).
	VSB or VSC –pump: The higher pressure transmitter gives the full signal (20 mA) or the lower pressure transmitter gives no signal.	Check the connections and transmitters. Measure the signals of the transmitter and if needed, change the transmitter.

Trouble	Fault	Fixing
The pump is not pumping.	There is air in the pump or the system.	Deairate the system. Fill the pumps and the pipes with the fluid. Try to run the pump a moment with the high speed, then possible air pockets leave the system easier.
	The suction pressure is too low.	Increase the suction pressure.
	Circulation is closed with the valves.	Open the valves.
The pump is noisy.	Cavitation.	Increase the suction pressure. Decrease the flow.
	The pressure difference of the pump is too high.	Decrease the pressure reference. If possible, open the control valves



		and decrease the pressure reference, then the head of the pump is lower and the flow remains the same.
	There is a faulty shaft seal or bearings.	Continuous rough noise refers to the faulty bearings. High noise, few seconds long, occasionally refers to the faulty shaft seal. Replace faulty bearings and shaft seal with the new ones. If necessary, contact Kolmeks.
	Electrical noise from the frequency converter or electric motor.	Replace the motor with the new one. If necessary, correct the parameters of the frequency converter. Contact Kolmeks.

6.4 Checking of alarm history

Push MODE –button twice. To the display appears the last 8 alarms. The last one is E.xxx. If there is no alarms, there is E__0 in the display.

6.5 Alarm and fault codes

Fault code	Fault name	Subcode	Possible cause	Remedy
1	Overcurrent		AC drive has detected too high a current ($>4 \cdot I_M$) in the motor cable: <ul style="list-style-type: none"> sudden heavy load increase short circuit in motor cables unsuitable motor 	Check loading. Check motor. Check cables and connections. Make identification run. Check ramp times.
2	Overvoltage		The DC-link voltage has exceeded the limits defined. <ul style="list-style-type: none"> too short a deceleration time brake chopper is disabled high overvoltage spikes in supply Start/Stop sequence too fast 	Make deceleration time longer. Use brake chopper or brake resistor (available as options). Activate overvoltage controller. Check input voltage.
3	Earth fault		Current measurement has detected that the sum of motor phase current is not zero. <ul style="list-style-type: none"> insulation failure in cables or motor 	Check motor cables and motor.
8	System Fault	84	MPI communication crc error	Reset the fault and restart. Should the fault re-occur, contact the distributor near to you.
		89	HMI receives buffer overflow	Check PC-drive cable. Try to reduce ambient noise
		90	Modbus receives buffer overflow	Check Modbus specifications for time-out. Check cable length. Reduce ambient noise. Check baudrate.
		93	Power identification error	Try to reduce ambient noise. Reset the fault and restart. Should the fault re-occur, contact the distributor near to you.
		97	MPI off line error	Reset the fault and restart. Should the fault re-occur, contact the distributor near to you.
		98	MPI driver error	Reset the fault and restart. Should the fault re-occur, contact the distributor near to you.
		99	Option board driver error	Check contact in option board slot Try to reduce ambient noise; Reset the fault and restart. Should the fault re-occur, contact the distributor near to you.



Fault code	Fault name	Subcode	Possible cause	Remedy
8	System Fault	100	Option board configuration error	Check contact in option board slot Try to reduce ambient noise; Should the fault re-occur, contact the distributor near to you.
		101	Modbus buffer overflow	Check Modbus specifications for time-out. Check cable length. Reduce ambient noise. Check baudrate.
		104	Option board channel full	Check contacts in option board slot. Try to reduce ambient noise. Should the fault re-occur, contact the distributor near to you.
		105	Option board memory allocation fail	Check contacts in option board slot. Try to reduce ambient noise. Should the fault re-occur, contact the distributor near to you.
		106	Option board Object queue full	Check contacts in option board slot. Try to reduce ambient noise. Should the fault re-occur, contact the distributor near to you.
		107	Option board HMI queue full	Check contacts in option board slot. Try to reduce ambient noise. Should the fault re-occur, contact the distributor near to you.
		108	Option board SPI queue full	Check contacts in option board slot. Try to reduce ambient noise. Should the fault re-occur, contact the distributor near to you.
		111	Parameter copy error	Check if parameter set is compatible with drive. Do not remove Keypad until copy is finished.
		113	Frequency detective timer overflow	Check keypad contacts. Try to reduce ambient noise. Should the fault re-occur, contact the distributor near to you.
		114	PC control time out fault	Do not close Vacon Live when PC control is active. Check PC-Drive cable. Try to reduce ambient noise.
115	DeviceProperty data format	Reset the fault and restart. Should the fault re-occur, contact the distributor near to you.		

Fault code	Fault name	Subcode	Possible cause	Remedy
8	System Fault	120	Task stack overflow	Reset the fault and restart. Should the fault re-occur, contact the distributor near to you.
9	Undervoltage		DC-link voltage is under the voltage limits defined. <ul style="list-style-type: none"> • most probable cause: too low a supply voltage • AC drive internal fault • defect input fuse • external charge switch not closed NOTE! This fault is activated only if the drive is in Run state.	In case of temporary supply voltage break reset the fault and restart the AC drive. Check the supply voltage. If it is adequate, an internal failure has occurred. Contact the distributor near to you.
10	Input phase		Input line phase is missing.	Check supply voltage, fuses and cable.
11	Output phase		Current measurement has detected that there is no current in one motor phase.	Check motor cables and motor.
13	AC drive undertemperature		Too low temperature measured in power unit's heatsink or board. Heatsink temperature is under -10°C.	Check the ambient temperature.
14	AC drive overtemperature		Too high temperature measured in power unit's heatsink or board. Heatsink temperature is over 100°C.	Check the correct amount and flow of cooling air. Check the heatsink for dust. Check the ambient temperature. Make sure that the switching frequency is not too high in relation to ambient temperature and motor load.
15	Motor stalled		Motor is stalled.	Check motor and load. Insufficient motor power, check motor stall protection parametrization.
16	Motor overtemperature		Motor is overloaded.	Decrease motor load. If no motor overload exists, check the temperature model parameters.
17	Motor underload		Motor is under loaded	Check load. Check underload protection parametrization.
19	Power overload		Supervision for drive power	Drive power is too high: decrease load.
25	Watchdog		Error in the microprocessor monitoring Malfunction Component fault	Reset the fault and restart. If the fault occurs again, please contact your closest Vacon representative.
27	Back EMF		Protection of unit when starting with rotating motor	Reset the fault and restart. Should the fault re-occur, contact the distributor near to you.

Fault code	Fault name	Subcode	Possible cause	Remedy
30	STO fault		Safe torque off signal does not allow drive to be set as ready	Reset the fault and restart. Should the fault re-occur, contact the distributor near to you.
35	Application error	0	Firmware Interface version between Application and Control not matching	Load a compatible application. Please contact your closest Vacon representative.
		1	Application software flash error	Reload Application
		2	Application header error	Load a compatible application. Please contact your closest Vacon representative.
41	IGBT temp		IGBT temperature (UnitTemperature + I2T) too high	Check loading. Check motor size. Make identification run.
50	4 mA fault (Analog input)		Selected signal range: 4...20 mA (see Application Manual) Current less than 4 mA Signal line broken detached The signal source is faulty	Check the analog input's current source and circuit.
51	External fault		Error message on digital input. The digital input was programmed as an input for external error messages. The input is active.	Check the programming and check the device indicated by the error message. Check the cabling for the respective device as well.
52	Keypad Communication fault		The connection between the control keypad and the frequency converter is broken.	Check keypad connection and keypad cable.
53	Fieldbus communication fault		The data connection between the fieldbus master and fieldbus board is broken	Check installation and fieldbus master.
54	Fieldbus Interface error		Defective option board or slot	Check board and slot.
55	Wrong run command		Wrong run alarm and stop command	Run forward and backward are activated at the same time
56	Temperature		Temperature fault	Board OPTBH is installed and measured temperature is above (or below) the limit
57	Identification		Identification alarm	Motor identification has not been successfully completed
63	Quick Stop		Quick Stop activated	The drive has been stopped with Quick Stop digital input or Quick Stop command by fieldbus

7. Declaration of Conformity

We, KOLMEKS OY, P.O.Box 27 FI-14201 Turenki, FINLAND
declare under our sole responsibility that the products:

VS_ - PUMP SERIE,

types AE, AEP, L, LH, LP, LS, AL, ALH, ALP, ALS

to which this declaration relates, are in conformity with the

- Council Directive 2006/42/EY on the approximation of the laws of the Member States relating to machinery
- Low voltage directive 2014/35/EU
- Pumps and pump units for liquids. Common safety requirements. EN 809:1998+A1:2009.
- Ecodesing directive 2009/125/EY Regulations: 547/2012 for water pumps
640/2009 for electric motors
- RoHS-directive 2011/65/EC

Serial / manufacturing number _____

EMC-STANDARDS

Generic standards

The generic standards are stated in the EMC directive (2014/30/EU).

VS_ -pump complies with:

EN 61000-6-3, EN 61000-6-1. Residential, commercial and light industrial environment.

EN 61000-6-4, EN 61000-6-2. Industrial environment.

Turenki 12.03.2019



Jyrki Vesaluoma
Chairman of the board

Technical file collected by R&D manager

KOLMEKS OY
P.O.BOX 27 FI-14201 TURENKI, FINLAND
tel. +358 20 7521 31
www.kolmeks.fi
export.finland@kolmeks.com

MINIMUM EFFICIENCY INDEX MEI

The efficiency of a pump with a trimmed impeller is usually lower than that of a pump with full impeller diameter. The trimming of the impeller will adapt the pump to a fixed duty point, leading to reduced energy consumption. The minimum efficiency index (MEI) is based on full impeller diameter.

The operation of this water pump with variable duty points may be more efficient and economic when controlled, for example, by the use of a variable speed drive that matches the pump duty to the system.

For pumps supplied after 1.1.2015 regulation 547/2012 is to be applied, Minimum Efficiency Index MEI > 0,4, benchmark for the most efficient water pumps is MEI > 0,7. Information on benchmark efficiency is available at: www.europump.org/efficiencycharts

8. Annex

8.1 Wiring diagram VSA-single pump

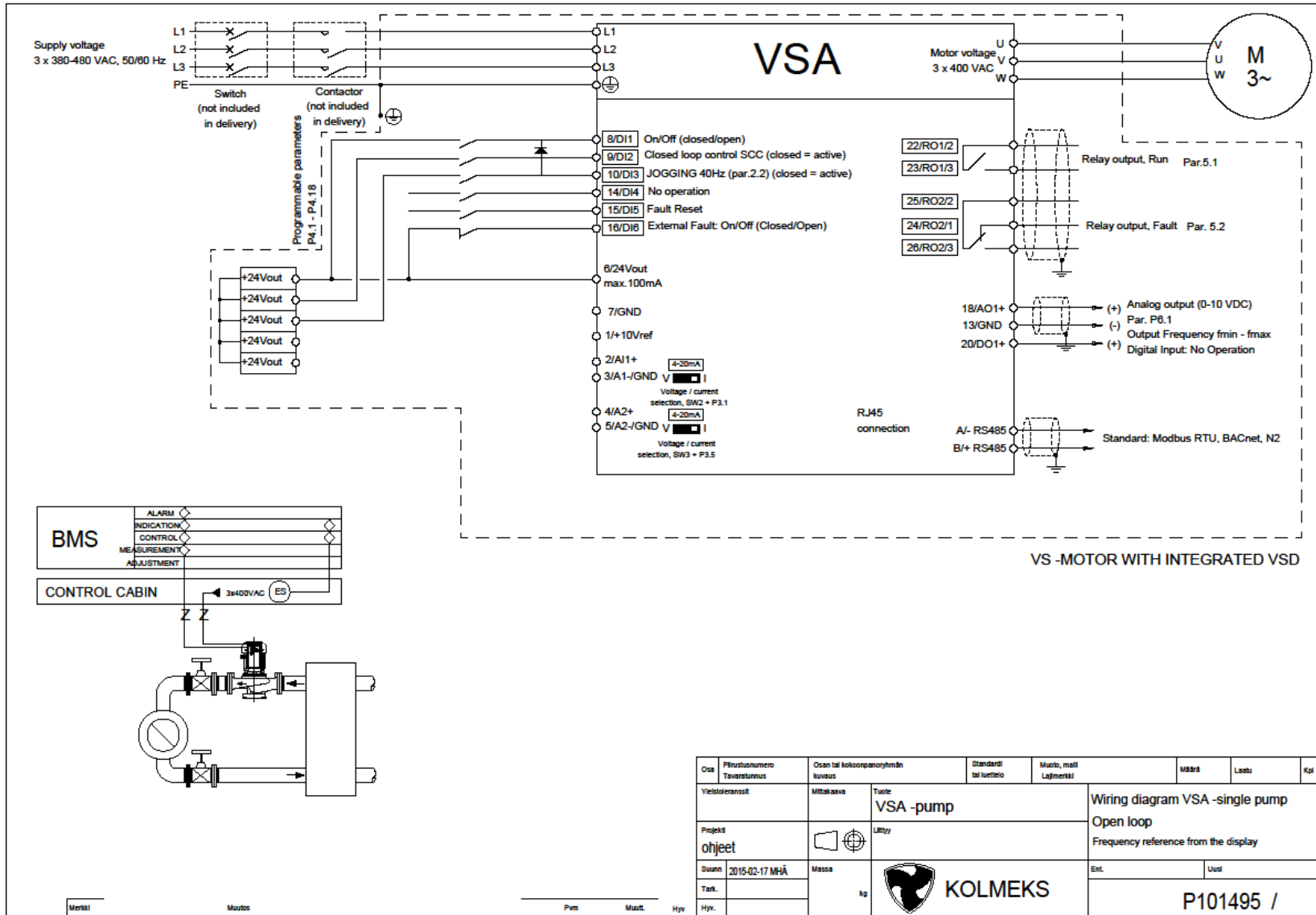

8.2 Wiring diagram VSB-single pump

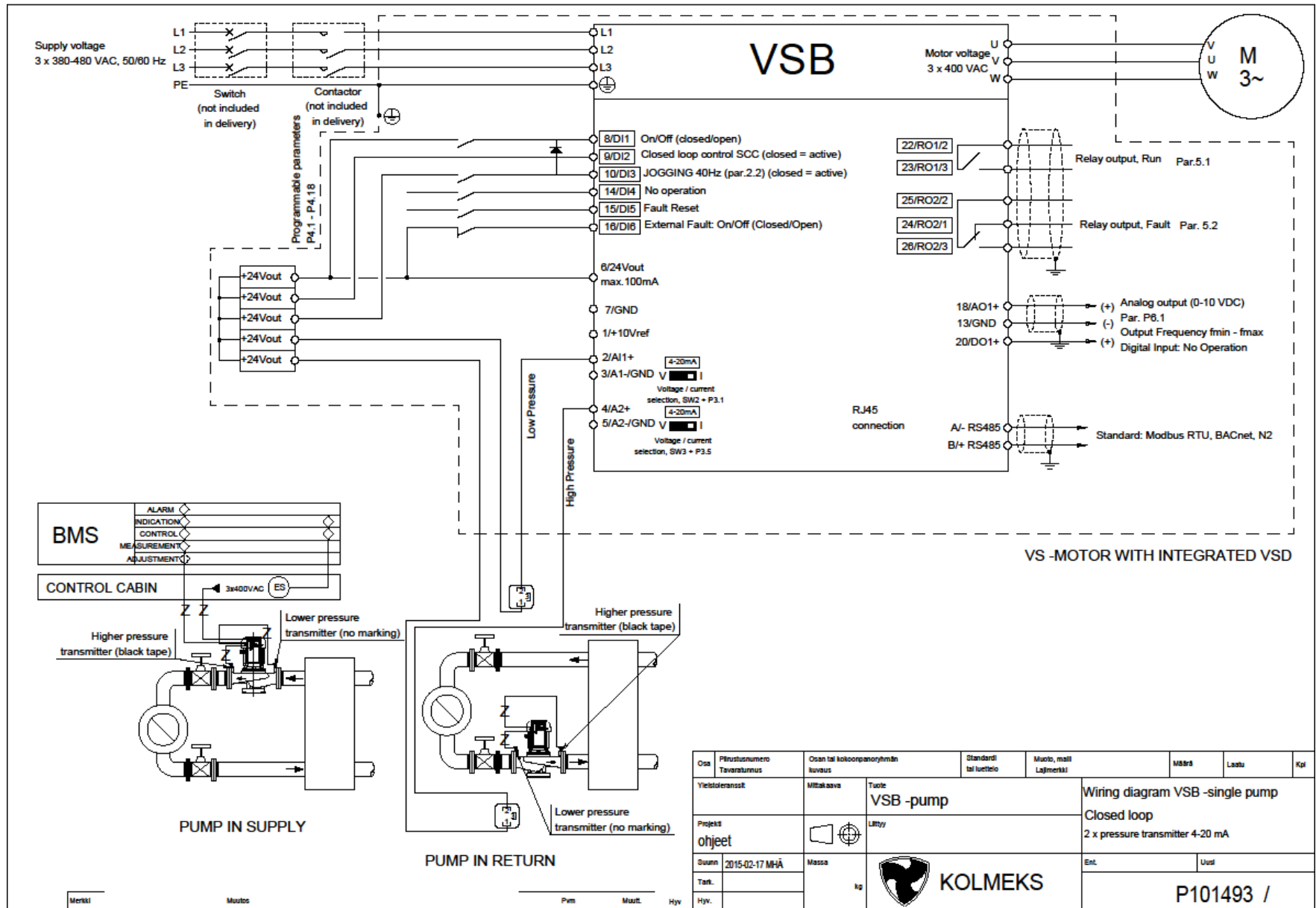

8.3 Wiring diagram VSC-single pump

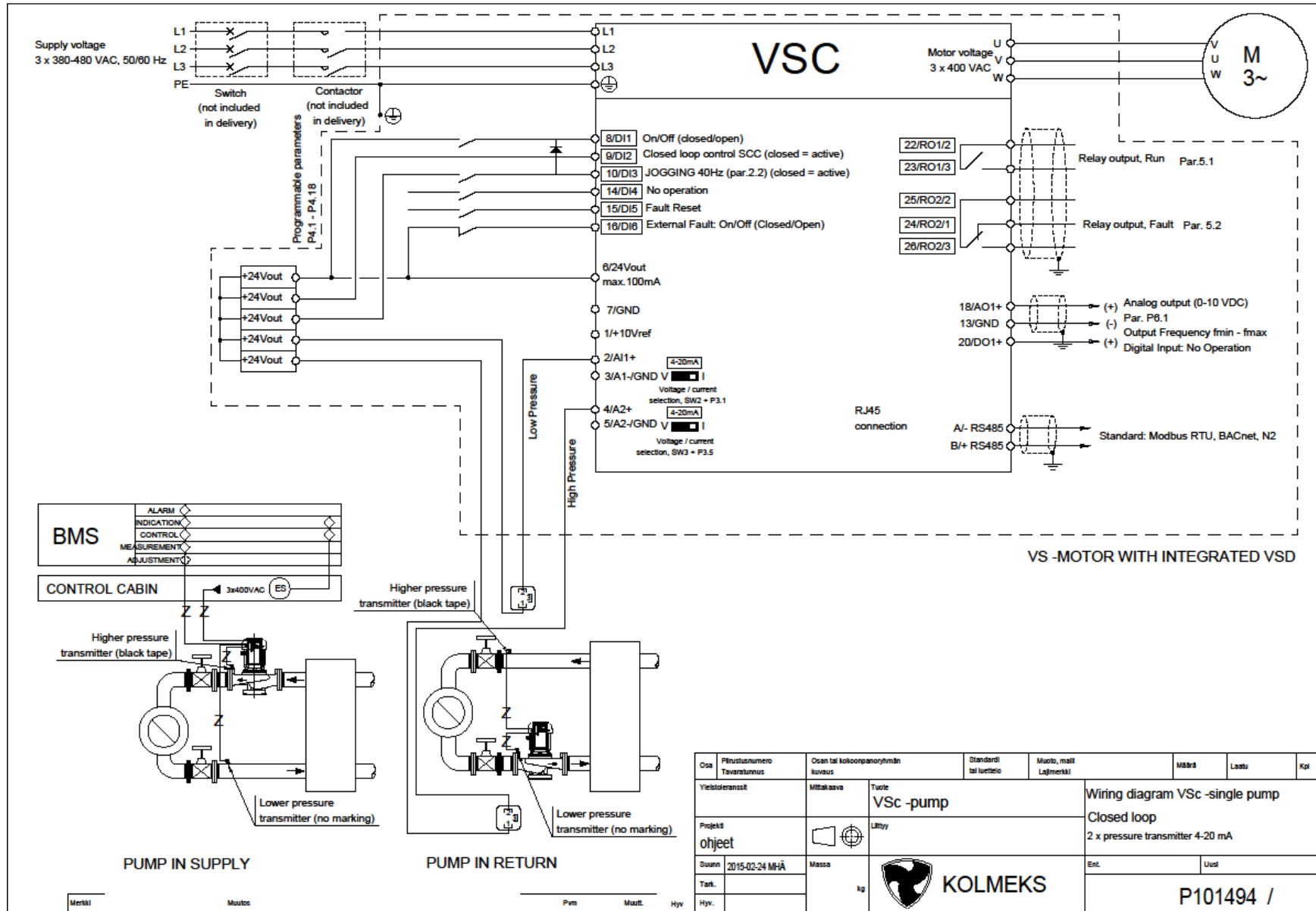

8.4 Wiring diagram VSD-single pump

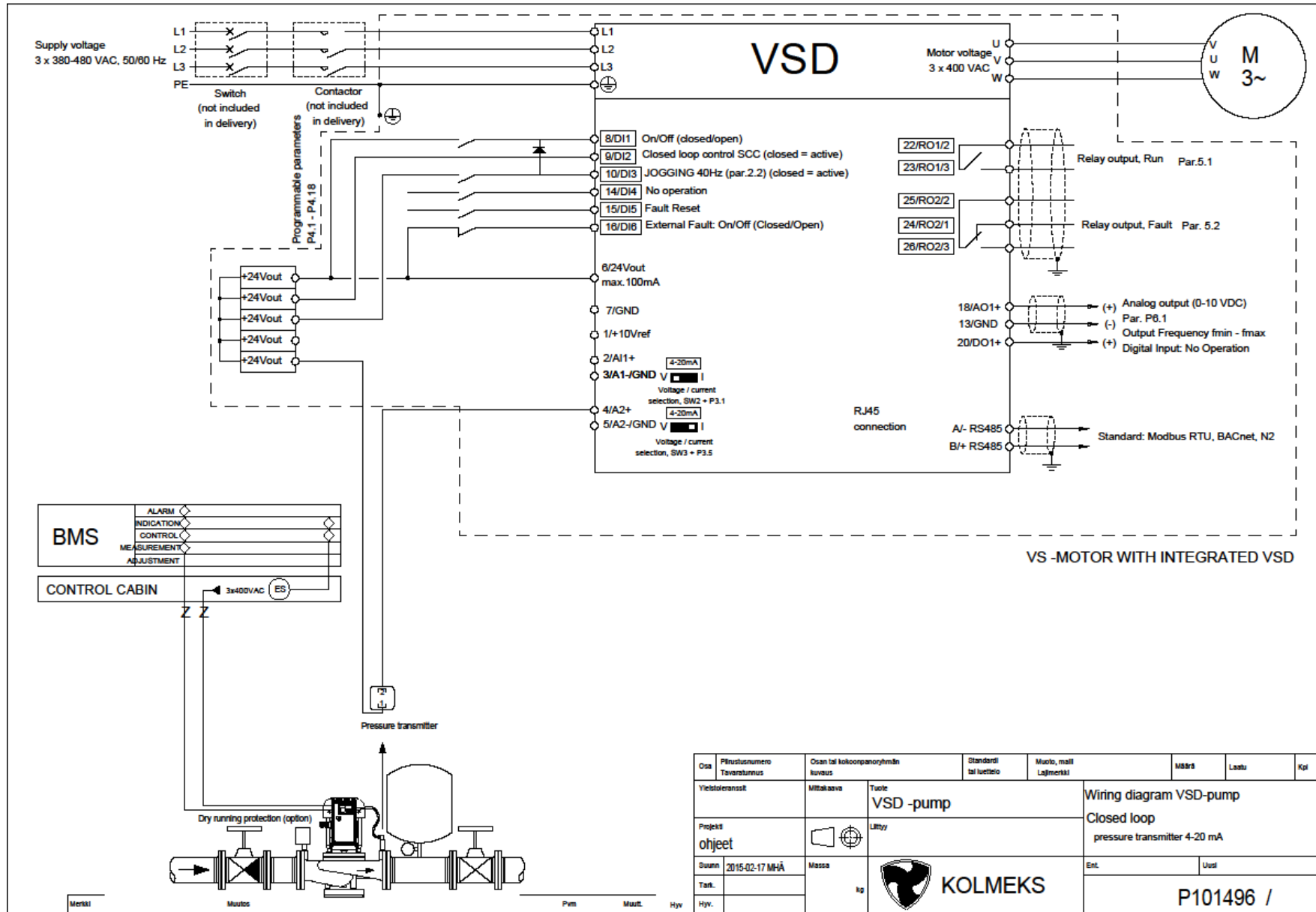

8.5 Wiring diagram VSF-single pump

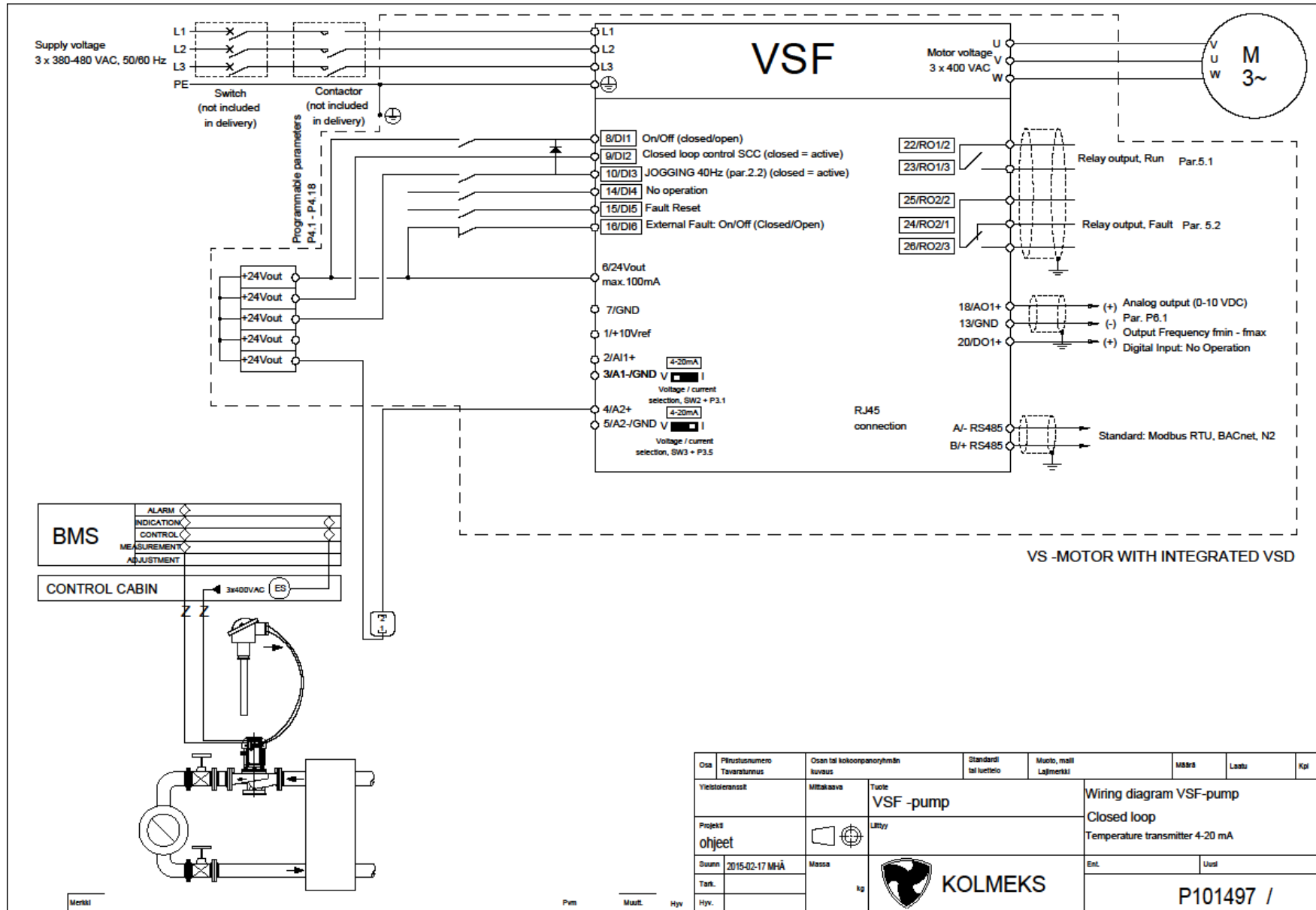

8.6 Wiring diagram VSG-single pump

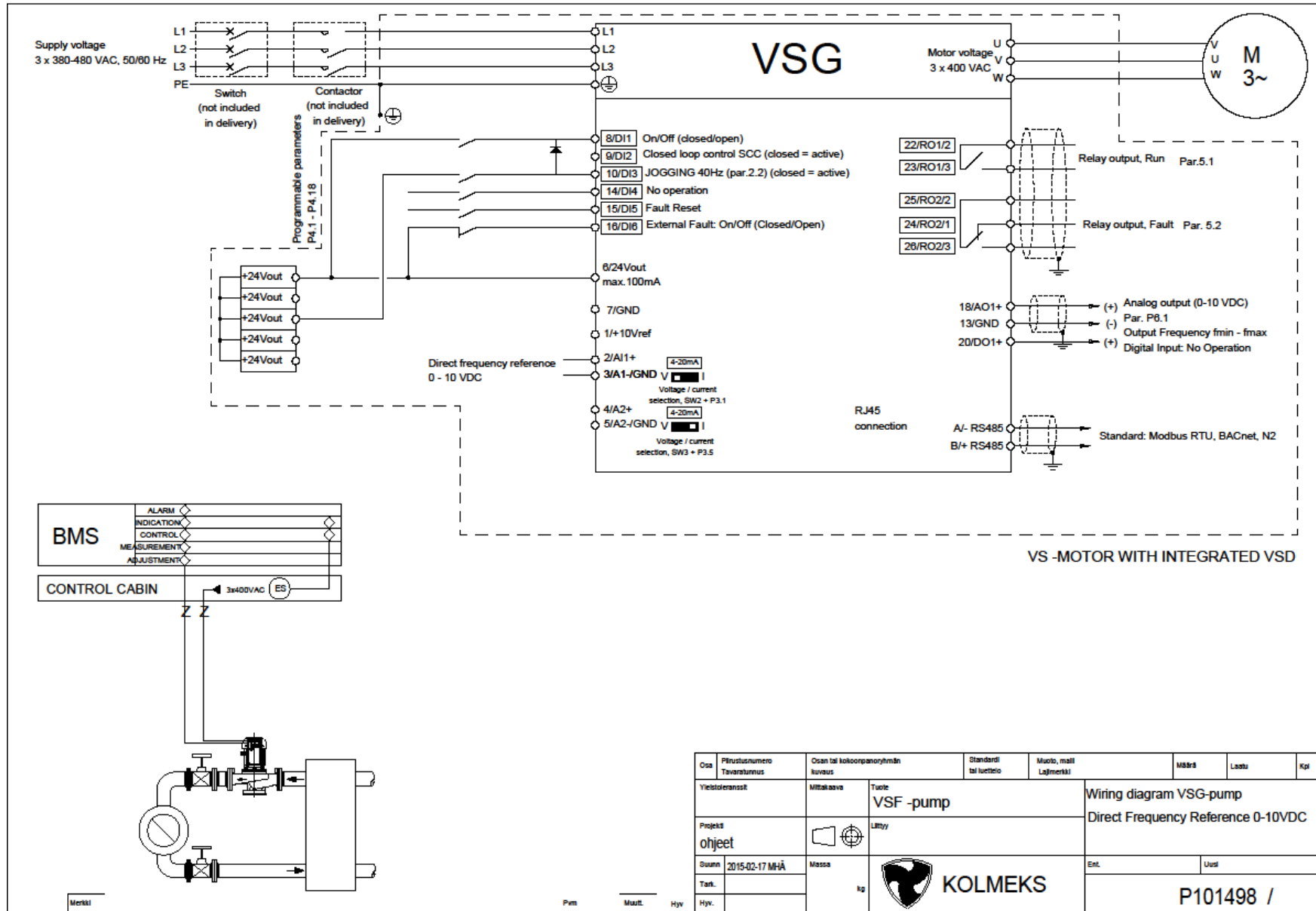

8.7 Wiring diagram VSM-single pump

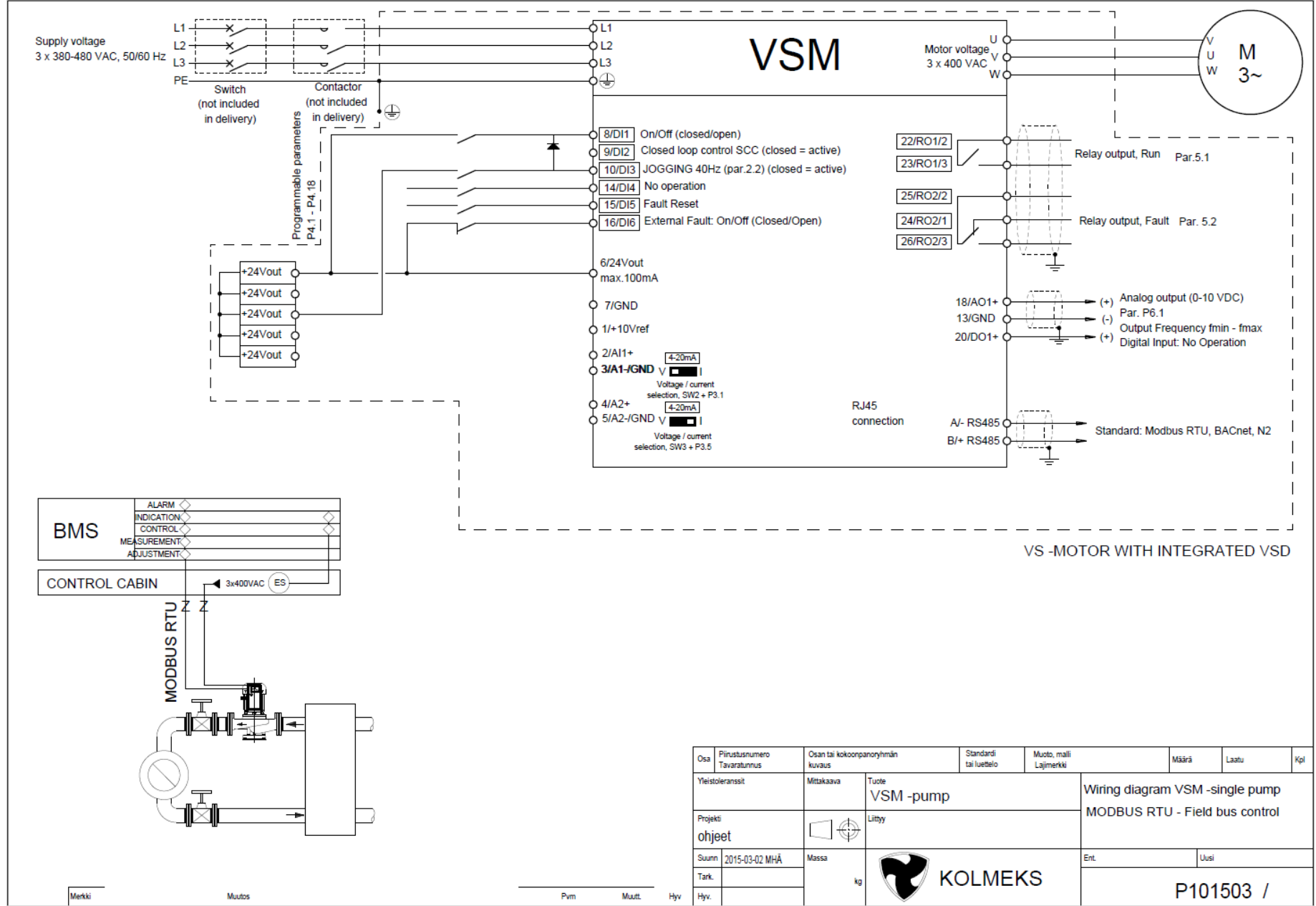

Osa	Piirustusnumero Tavaratunnus	Osan tai kokoonpanoryhmän kuvaus	Standardi tai luettelo	Muoto, malli Lajimerkki	Määrä	Laatu	Kpl
Yleistoleranssit	Mittakaava	Tuote VSM -pump					Wiring diagram VSM -single pump MODBUS RTU - Field bus control
Projekti ohjeet		Lititty					
Suunn.	2015-03-02 MHÄ	Massa					Ent.
Tark.		kg					Uusi
Hyv.					KOLMEKS		P101503 /